



Series Circuits



In a series circuit, current follows only one path from the positive end of the battery toward the negative end. The total resistance of a series circuit is equal to the sum of the individual resistances. The amount of energy used by a series circuit must equal the energy supplied by the battery. In this way, electrical circuits follow the law of conservation of energy. Understanding these facts will help you solve problems that deal with series circuits.

To answer the questions in the practice section, you will have to use Ohm's law. Remember that:

$$\text{Current (amps)} = \frac{\text{Voltage (volts)}}{\text{Resistance (ohms)}}$$

Some questions ask you to calculate a *voltage drop*. We often say that each resistor (or light bulb) creates a separate voltage drop. As current flows along a series circuit, each resistor uses up some energy. As a result, the voltage gets lower after each resistor. If you know the current in the circuit and the resistance of a particular resistor, you can calculate the voltage drop using Ohm's law.

$$\text{Voltage drop across resistor (volts)} = \text{Current through resistor (amps)} \times \text{Resistance of one resistor (ohms)}$$

PRACTICE

- Use the series circuit pictured to the right to answer questions (a)-(e).
 - What is the total voltage across the bulbs?
 - What is the total resistance of the circuit?
 - What is the current in the circuit?
 - What is the voltage drop across each light bulb? (Remember that voltage drop is calculated by multiplying current in the circuit by the resistance of a particular resistor: $V = IR$.)
 - Draw the path of the current on the diagram.
- Use the series circuit pictured to the right to answer questions (a)-(e).
 - What is the total voltage across the bulbs?
 - What is the total resistance of the circuit?
 - What is the current in the circuit?
 - What is the voltage drop across each light bulb?
 - Draw the path of the current on the diagram.
- What happens to the current in a series circuit as more light bulbs are added? Why?
- What happens to the brightness of each bulb in a series circuit as additional bulbs are added? Why?

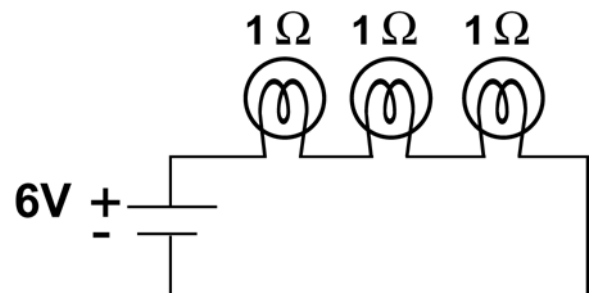
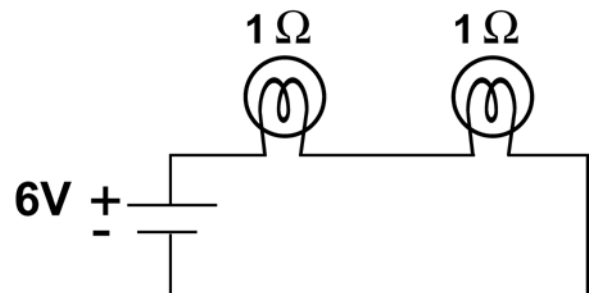



Page 2 of 2

5. Use the series circuit pictured to the right to answer questions (a), (b), and (c).

- What is the total resistance of the circuit?
- What is the current in the circuit?
- What is the voltage drop across each resistor?

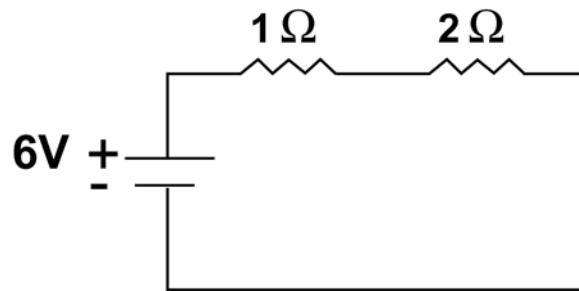

6. Use the series circuit pictured to the right to answer questions (a)-(e).

- What is the total voltage of the circuit?
- What is the total resistance of the circuit?
- What is the current in the circuit?
- What is the voltage drop across each light bulb?
- Draw the path of the current on the diagram.

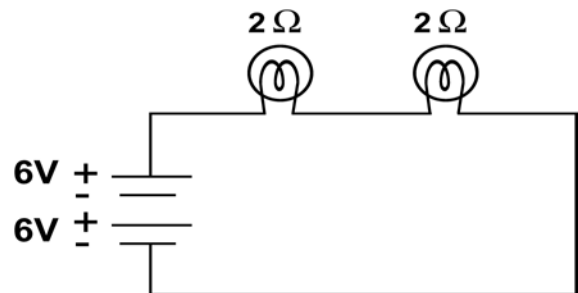

7. Use the series circuit pictured right to answer questions (a), (b), and (c). Consider each resistor equal to all others.

- What is the resistance of each resistor?
- What is the voltage drop across each resistor?
- On the diagram, show the amount of voltage in the circuit before and after each resistor.

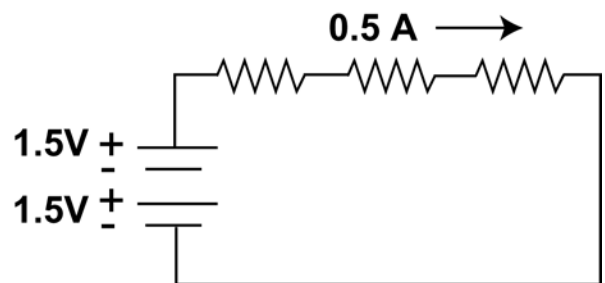

8. Use the series circuit pictured right to answer questions (a) - (d).

- What is the total resistance of the circuit?
- What is the current in the circuit?
- What is the voltage drop across each resistor?
- What is the sum of the voltage drops across the three resistors? What do you notice about this sum?

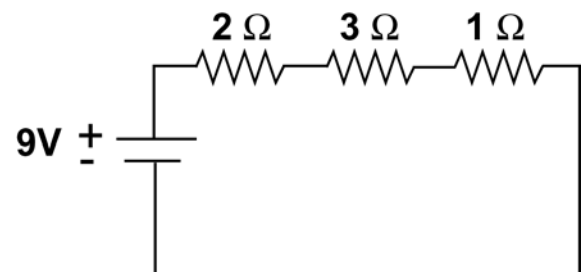

9. Use the diagram to the right to answer questions (a), (b), and (c).

- How much current would be measured in each circuit if each light bulb has a resistance of 6 ohms?
- How much current would be measured in each circuit if each light bulb has a resistance of 12 ohms?
- What happens to the amount of current in a series circuit as the number of batteries increases?

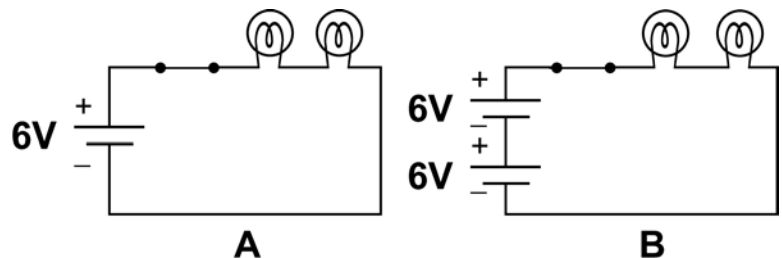

14.1 Series Circuits

1. Answers are:

- 6 volts
- 2 ohms
- 3 amps
- 3 volts
- Diagram:

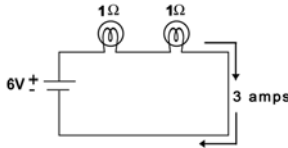

2. Answers are:

- 6 volts
- 3 ohms
- 2 amps
- 2 volts
- Diagram:

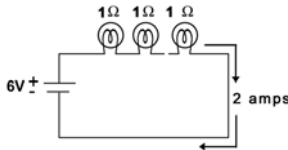

- The current decreases because the resistance increases.
- The brightness decreases because the voltage across each bulb decreases and the current decreases. Since power equals voltage times current, the power consumed also decreases.

5. Answers are:

- 3 ohms
- 2 amps
- 1 ohm bulb: 2 volts; 2 ohm bulb: 4 volts

6. Answers are:

- 12 volts
- 4 ohms
- 3 amps
- 6 volts

e. Diagram:

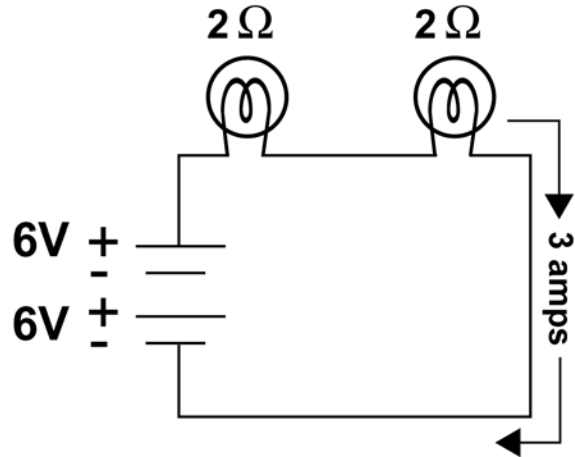

7. Answers are:

- 2 ohms
- 1 volt
- Diagram:

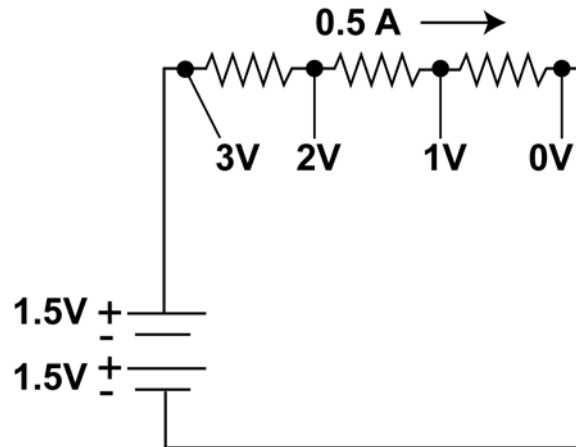

8. Answers are:

a. 6 ohms

b. 1.5 amps

c. 2 ohm resistor: 3 volts; 3 ohm resistor: 4.5 volts; 1 ohm resistor: 1.5 volt

d. The sum is 9 volts, the same as the battery voltage.

9. Answers are:

a. Diagram A: 0.5 amps; Diagram B: 1.0 amps

b. Diagram A: 0.25 amps; Diagram B: 0.5 amps

c. The amount of current increases.