

# Newton's Laws Review

An egg is dropped from a third-story window. The distance the egg falls from the window to the ground is closest to

(A)  $10^0$  mm

(B)  $10^2$  mm

(C)  $10^4$  mm

(D)  $10^6$  mm



An egg is dropped from a third-story window. The distance the egg falls from the window to the ground is closest to

(A)  $10^0$  mm

(B)  $10^2$  mm

**(C)  $10^4$  mm**

(D)  $10^6$  mm



A runner decreases her speed uniformly from 6.0 m/s to 1.0 m/s over a time of 4 seconds. The magnitude of her acceleration as she travels these 12 meters is

(A)  $1.9 \text{ m/s}^2$

(B)  $-1.2 \text{ m/s}^2$

(C)  $1.2 \text{ m/s}^2$

(D)  $3.8 \text{ m/s}^2$



A runner decreases her speed uniformly from 6.0 m/s to 1.0 m/s over a time of 4 seconds. The magnitude of her acceleration as she travels these 12 meters is

(A)  $1.9 \text{ m/s}^2$

**(B)  $-1.2 \text{ m/s}^2$**

(C)  $1.2 \text{ m/s}^2$

(D)  $3.8 \text{ m/s}^2$



Inertia

Which object has the most inertia?

- (A) a 0.001-kilogram bumblebee traveling at 2 meters per second
- (B) a 0.1-kilogram baseball traveling at 20 meters per second
- (C) a 5-kilogram bowling ball traveling at 3 meters per second
- (D) a 10-kilogram sled at rest

Which object has the most inertia?

- (A) a 0.001-kilogram bumblebee traveling at 2 meters per second
- (B) a 0.1-kilogram baseball traveling at 20 meters per second
- (C) a 5-kilogram bowling ball traveling at 3 meters per second
- (D) a 10-kilogram sled at rest**



A lab cart is loaded with different masses and moved at various velocities. Which diagram shows the cart-mass system with the greatest inertia?

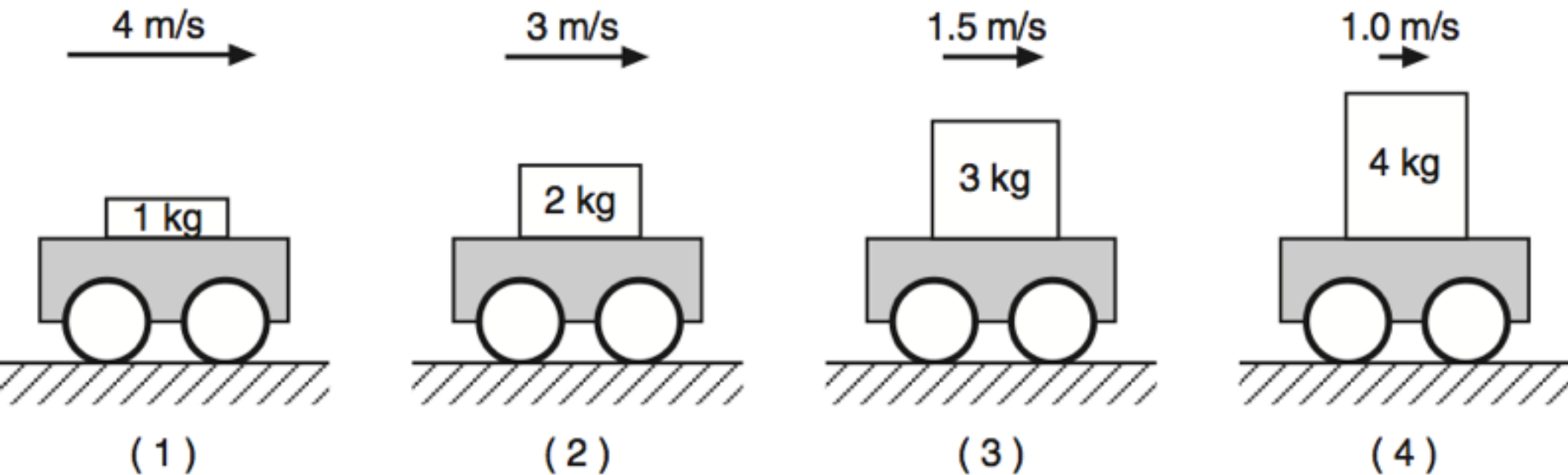

A lab cart is loaded with different masses and moved at various velocities. Which diagram shows the cart-mass system with the greatest inertia?

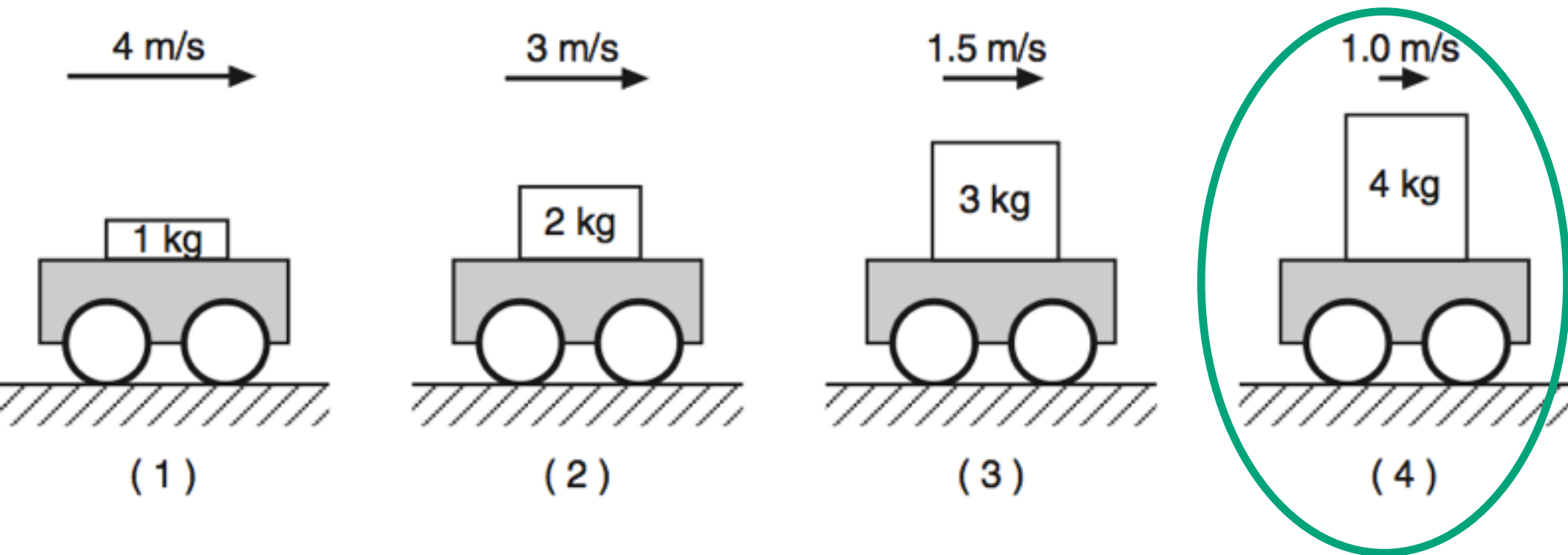

A 10-kilogram block is at rest on a plane inclined at  $15^\circ$  to the horizontal.

As the angle of the incline is increased to  $30^\circ$ , the mass of the block will

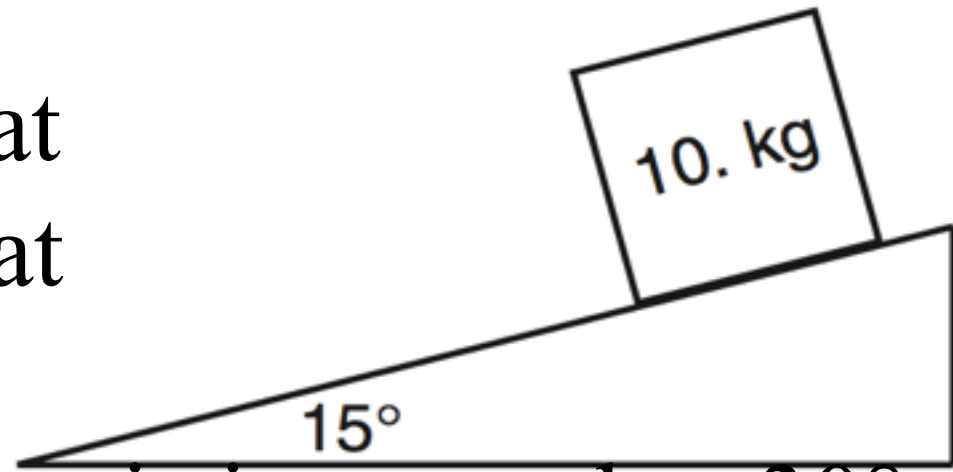

- (A) decrease
- (B) increase
- (C) remain the same

A 10-kilogram block is at rest on a plane inclined at  $15^\circ$  to the horizontal.

As the angle of the incline is increased to  $30^\circ$ , the mass of the block will

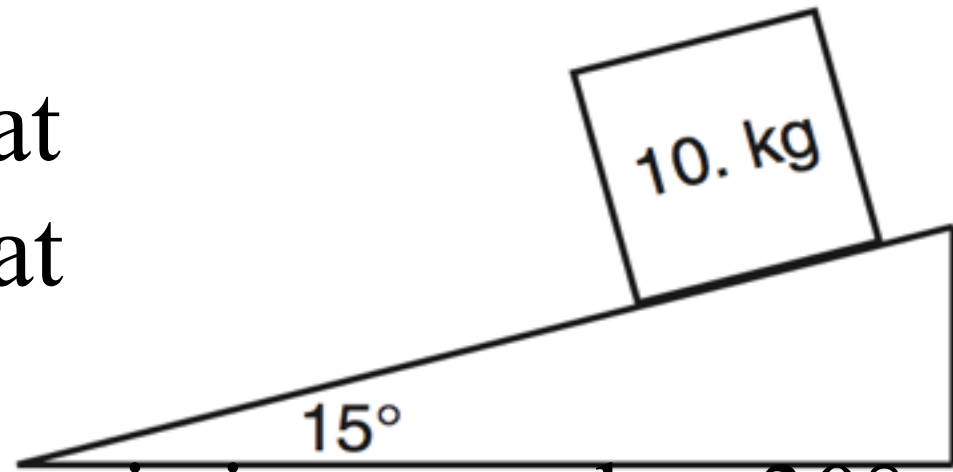

- (A) decrease
- (B) increase
- (C) remain the same**

Which object has the greatest inertia?

(A) a 5.00-kg mass moving at 10.0 m/s

(B) a 10.0-kg mass moving at 1.00 m/s

(C) a 15.0-kg mass moving at 10.0 m/s

(D) a 20.0-kg mass moving at 1.00 m/s



Which object has the greatest inertia?

- (A) a 5.00-kg mass moving at 10.0 m/s
- (B) a 10.0-kg mass moving at 1.00 m/s
- (C) a 15.0-kg mass moving at 10.0 m/s
- (D) a 20.0-kg mass moving at 1.00 m/s**

A 0.50-kilogram cart is rolling at a speed of 0.40 meters per second. If the speed of the cart is doubled, the inertia of the cart is

- (A) halved
- (B) doubled
- (C) quadrupled
- (D) unchanged



A 0.50-kilogram cart is rolling at a speed of 0.40 meters per second. If the speed of the cart is doubled, the inertia of the cart is

- (A) halved
- (B) doubled
- (C) quadrupled
- (D) unchanged**





Object	Mass (kg)	Speed (m/s)
A	4	6
B	6	5
C	8	4
D	10	1.5

Which object has the greatest inertia?

- (A) *A*
- (B) *B*
- (C) *C*
- (D) *D*



Object	Mass (kg)	Speed (m/s)
A	4	6
B	6	5
C	8	4
D	10	1.5

Which object has the greatest inertia?

- (A) *A*
- (B) *B*
- (C) *C*
- (D) *D***



**Net Force**

The vector diagram represents two forces,

$F_1$  and  $F_2$ , simultaneously acting on an object.

Which vector best represents the resultant of the two forces?

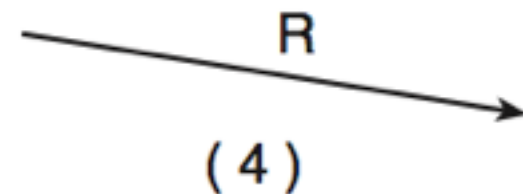
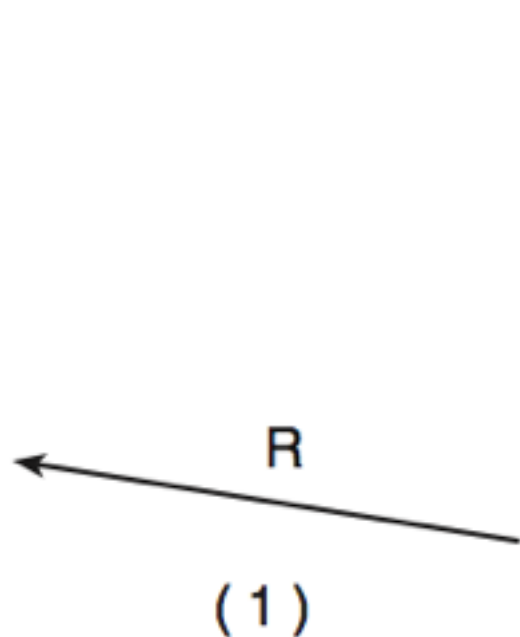
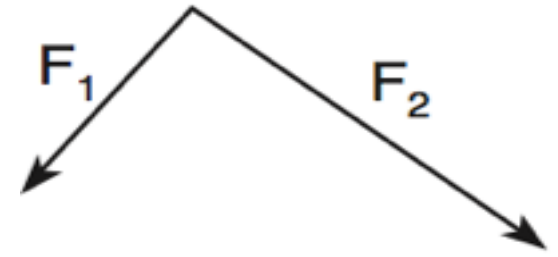

The vector diagram represents two forces,

$F_1$  and  $F_2$ , simultaneously acting on an object.

Which vector best represents the resultant of the two forces?

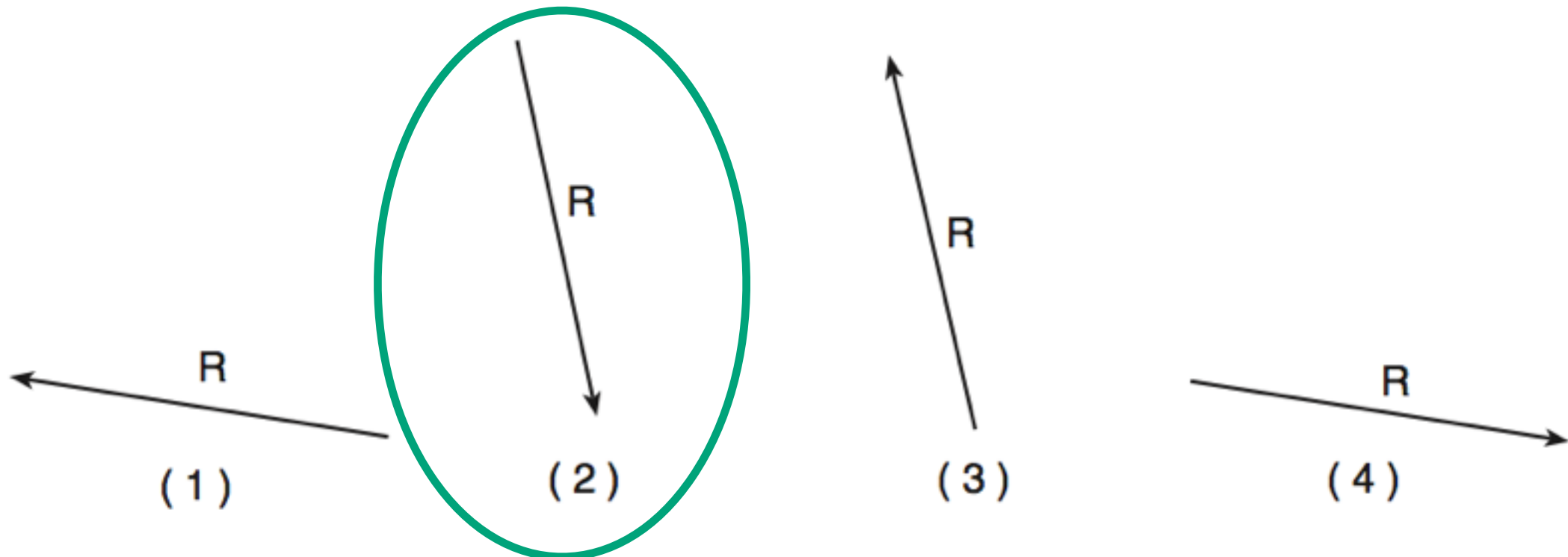
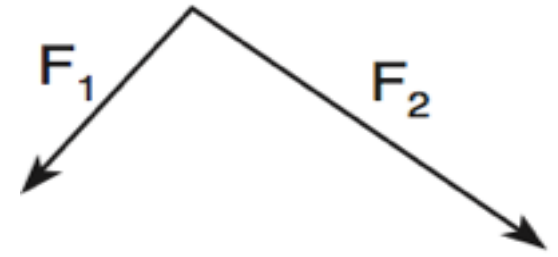

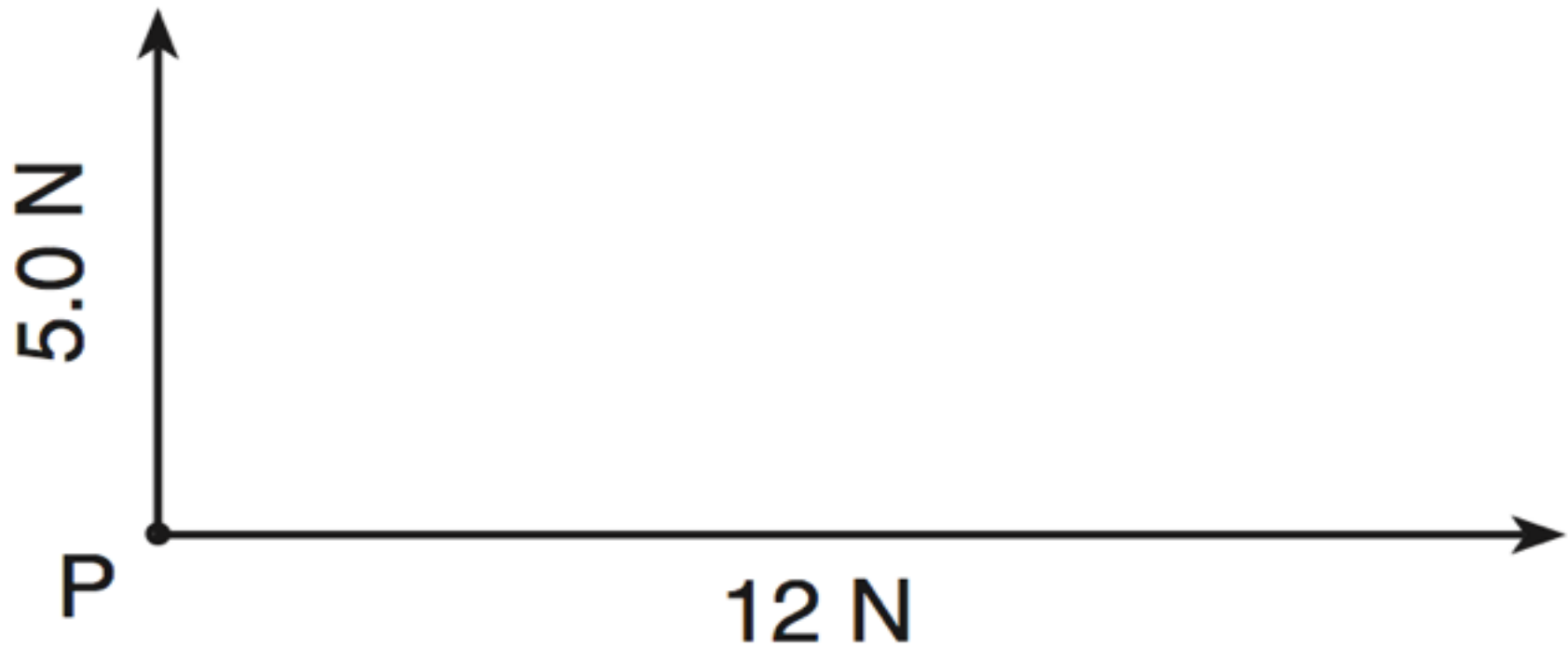

The diagram above represents a 5.0-N force and a 12-N force acting on point P. The resultant of the two forces has a magnitude of (A) 5.0-N (B) 7.0-N (C) 12-N (D) 13-N

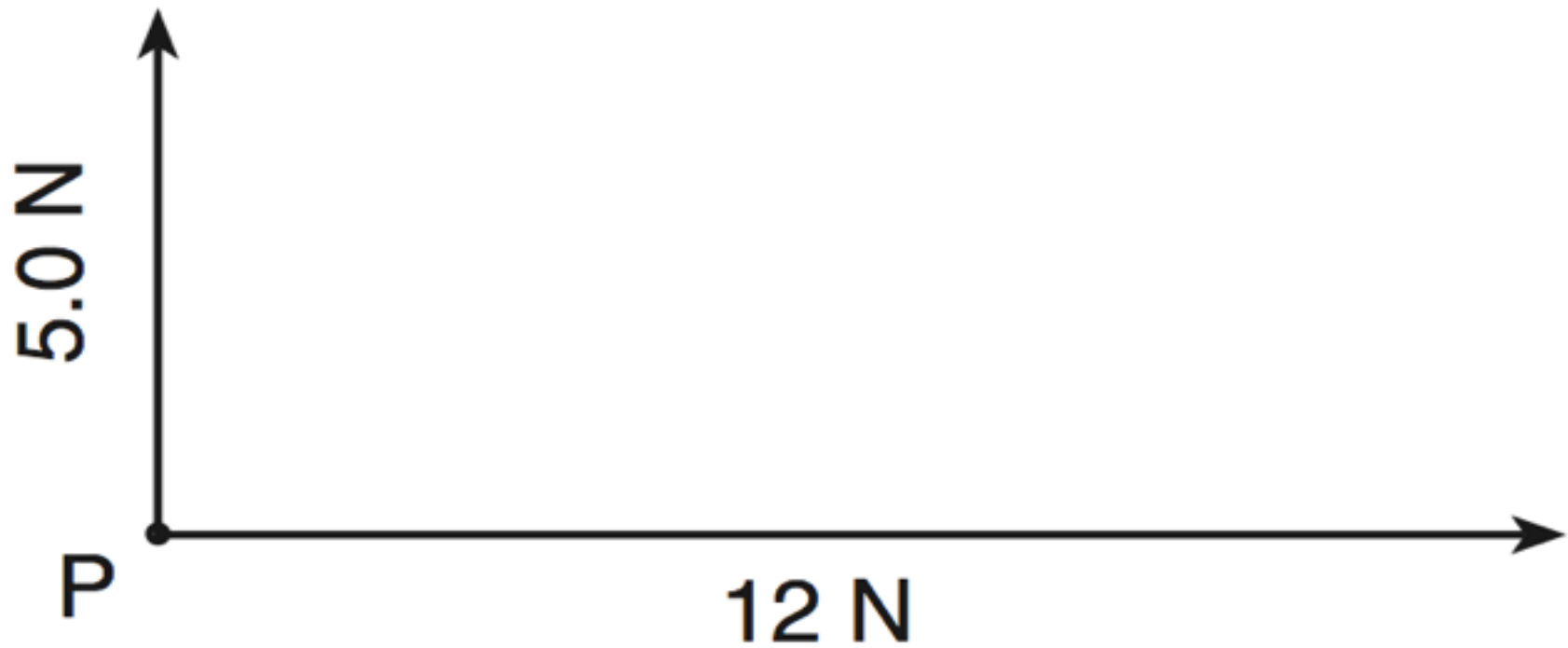

The diagram above represents a 5.0-N force and a 12-N force acting on point P. The resultant of the two forces has a magnitude of (A) 5.0-N (B) 7.0-N (C) 12-N (D) 13-N

The diagram above shows a 5.00-kilogram block at rest on a horizontal, frictionless table. Which diagram best represents the force exerted on the block by the table?

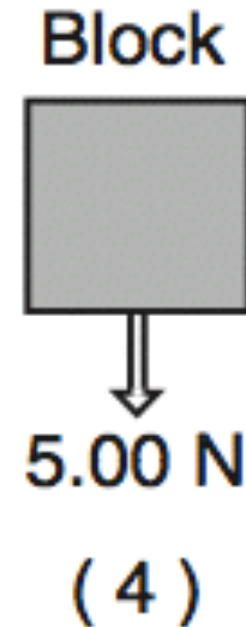
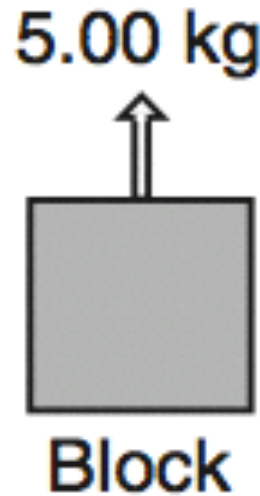
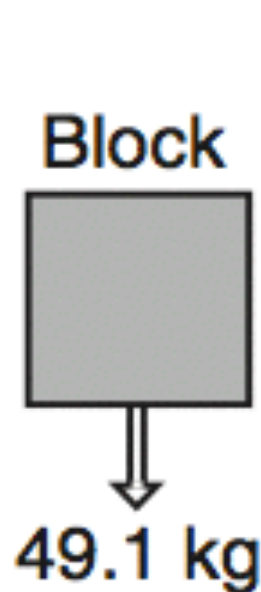
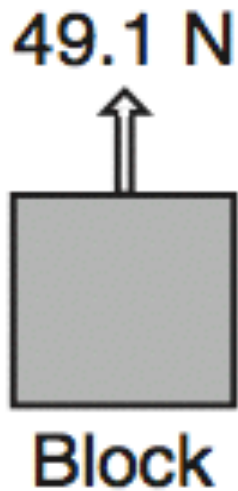
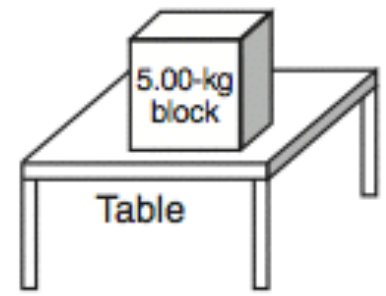



The diagram above shows a 5.00-kilogram block at rest on a horizontal, frictionless table. Which diagram best represents the force exerted on the block by the table?

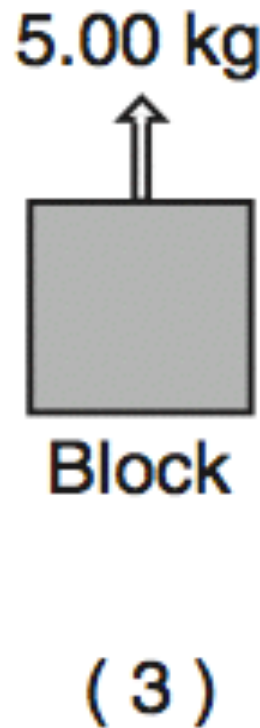
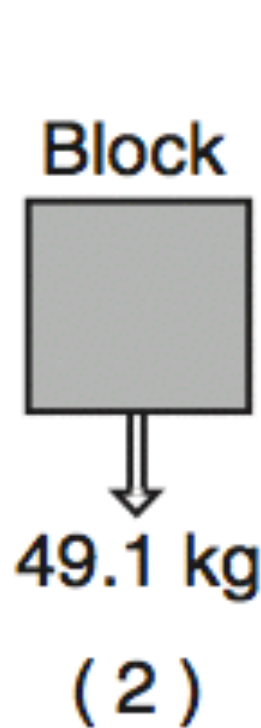
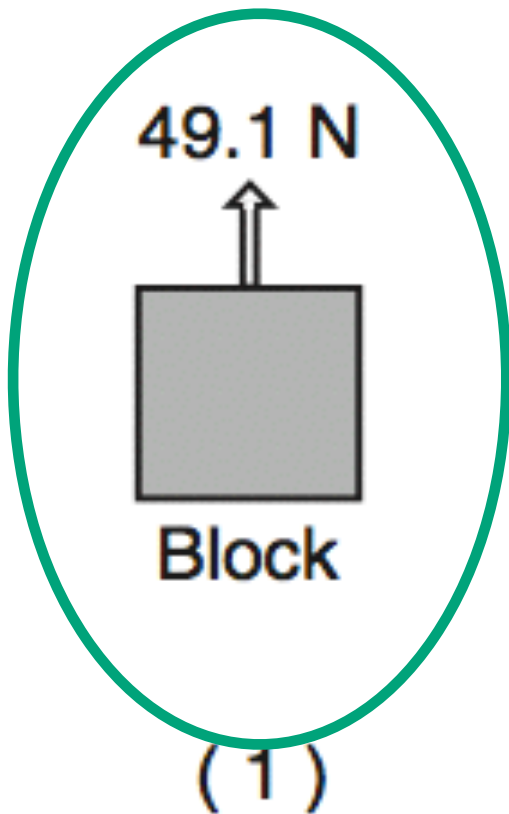
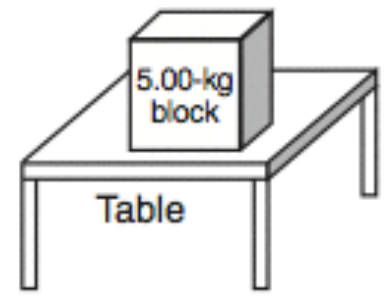

Which diagram represents a box in equilibrium?

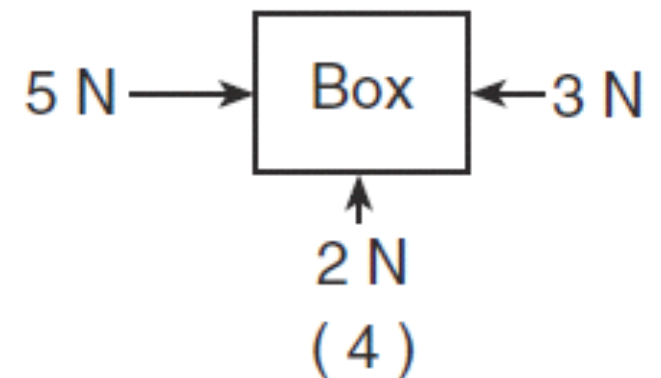
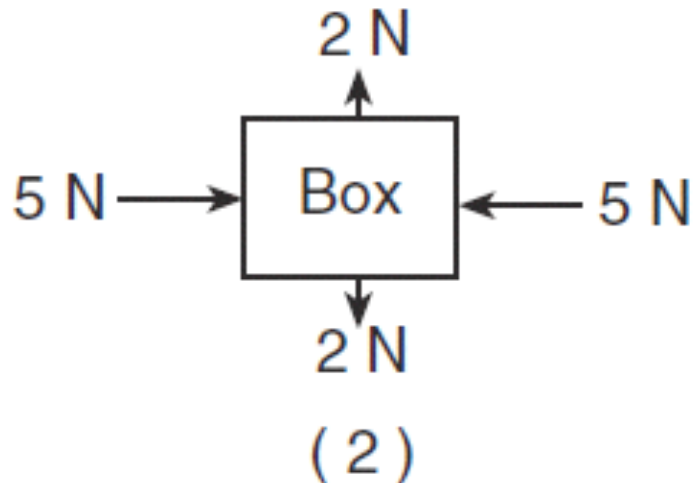
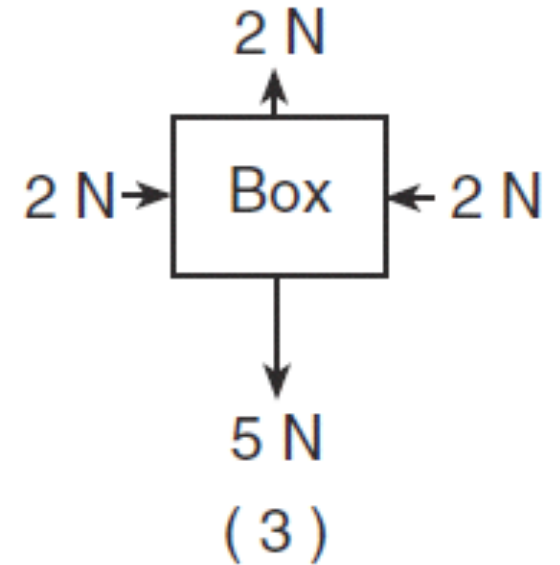
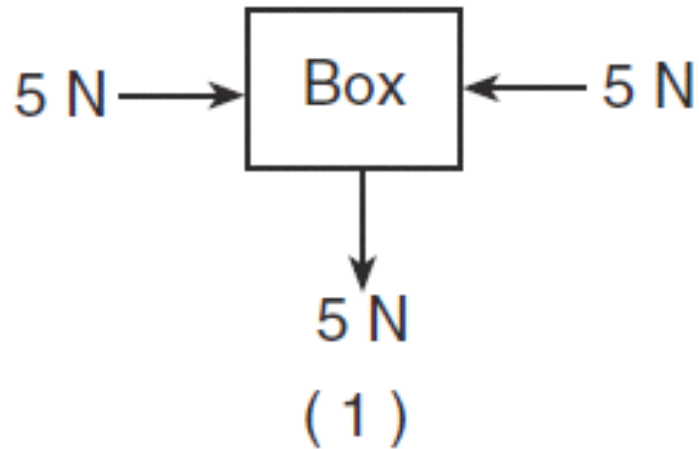

Which diagram represents a box in equilibrium?

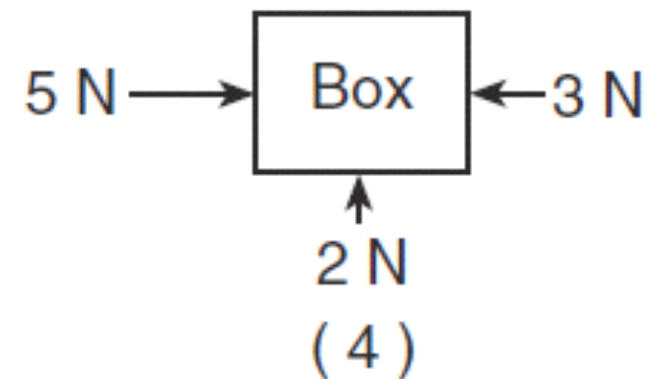
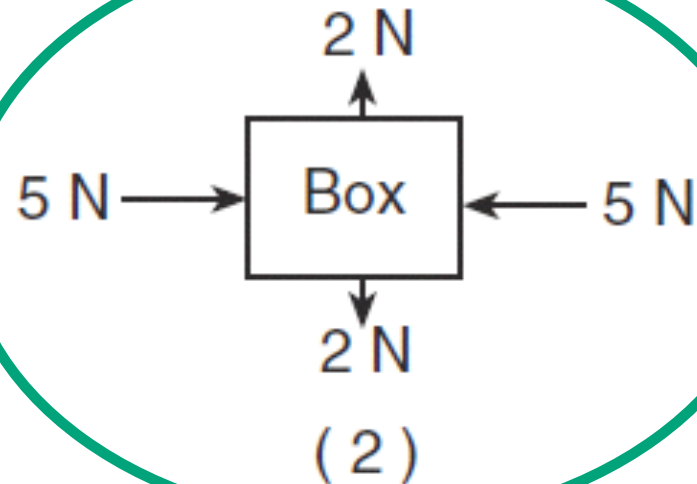
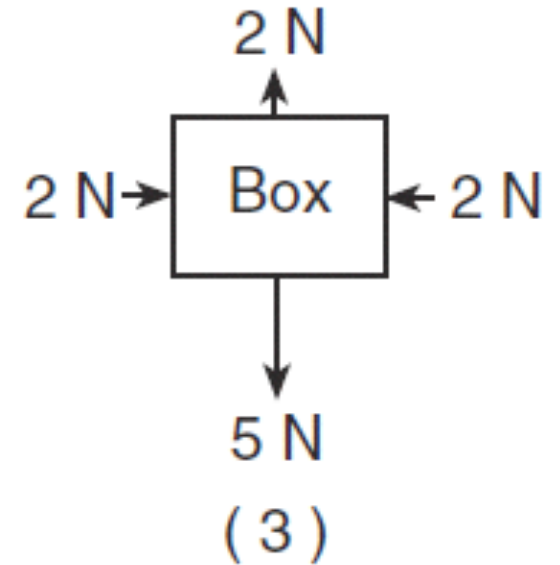
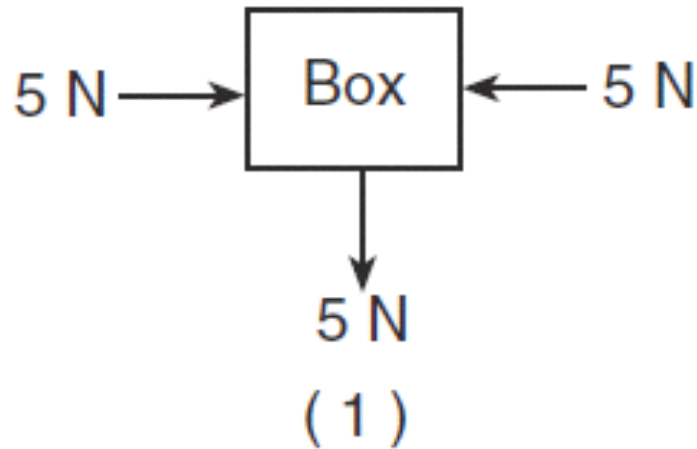

A 20-N force due north and a 20-N force due east act concurrently on an object. The additional force necessary to bring the object into a state of equilibrium is

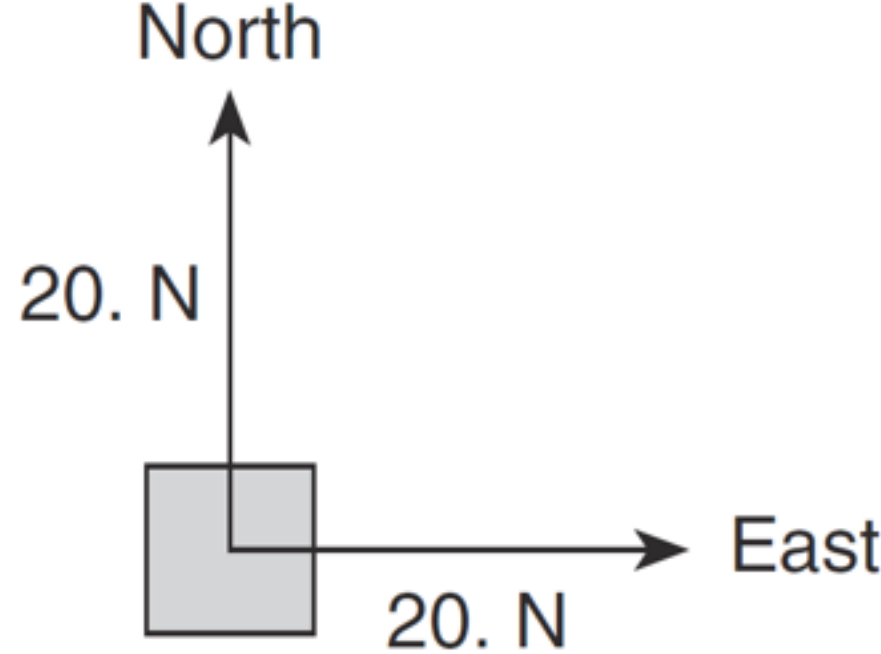

- (A) 20 N, northeast
- (B) 20 N, southwest
- (C) 28 N, northeast
- (D) 28 N, southwest

A 20-N force due north and a 20-N force due east act concurrently on an object. The additional force necessary to bring the object into a state of equilibrium is

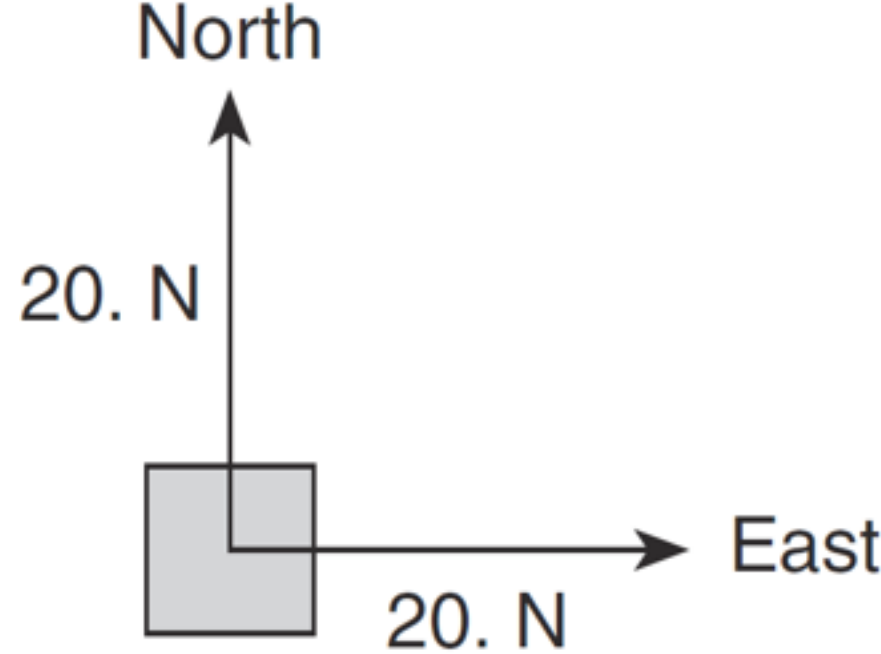

- (A) 20 N, northeast
- (B) 20 N, southwest
- (C) 28 N, northeast
- (D) 28 N, southwest**

A box is pushed toward the right across a classroom floor. The force of friction on the box is directed toward the

- (A) left
- (B) right
- (C) ceiling
- (D) floor

A box is pushed toward the right across a classroom floor. The force of friction on the box is directed toward the

- (A) left**
- (B) right
- (C) ceiling
- (D) floor

The diagram represents two concurrent forces.

Which vector represents the force that will produce

*equilibrium* with these two forces?

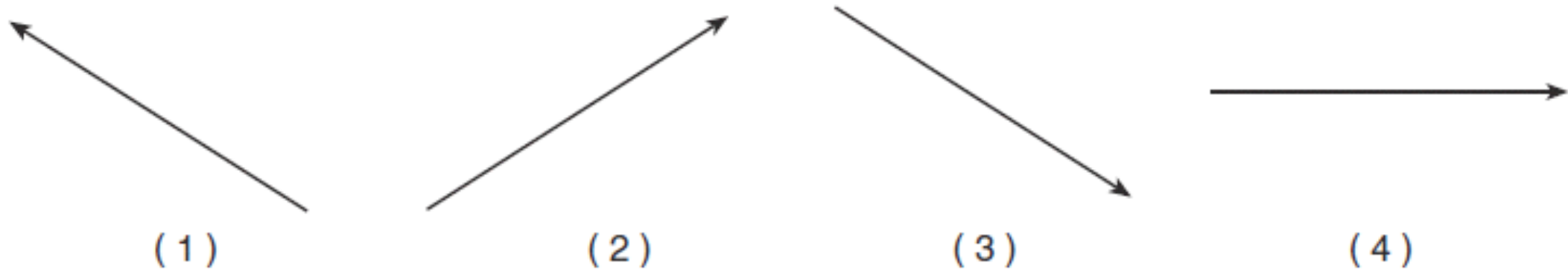



The diagram represents two concurrent forces.

Which vector represents the force that will produce

*equilibrium* with these two forces?

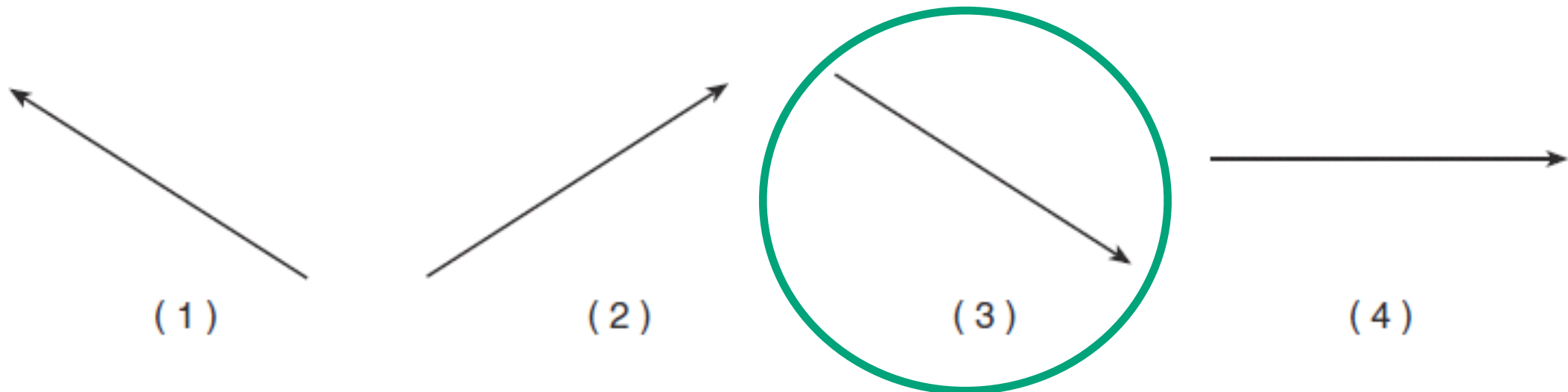

A sled and rider slide down a snow-covered hill that makes an angle of  $30^\circ$  with the horizontal. Which vector best represents the direction of the normal force,  $F_N$ , exerted by the hill on the sled?

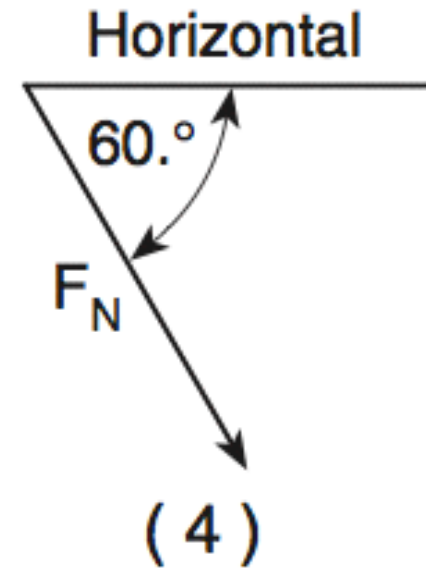
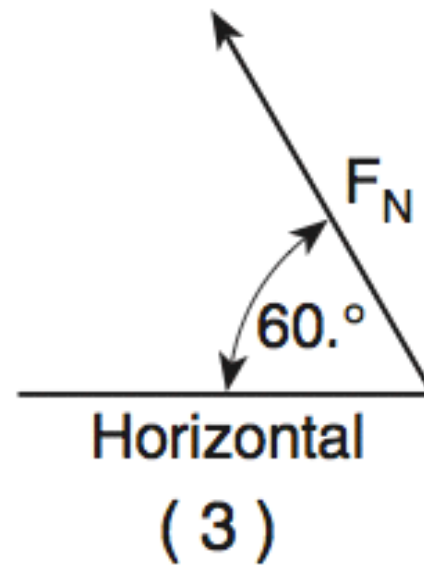
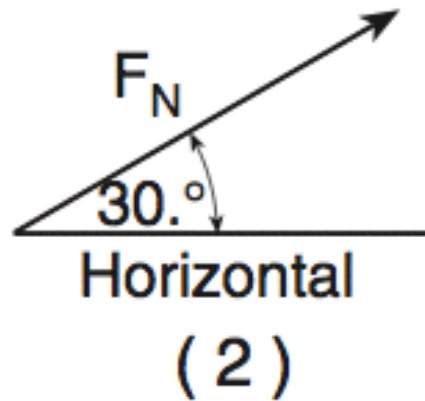
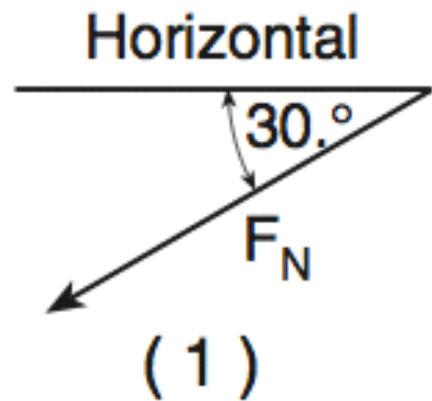
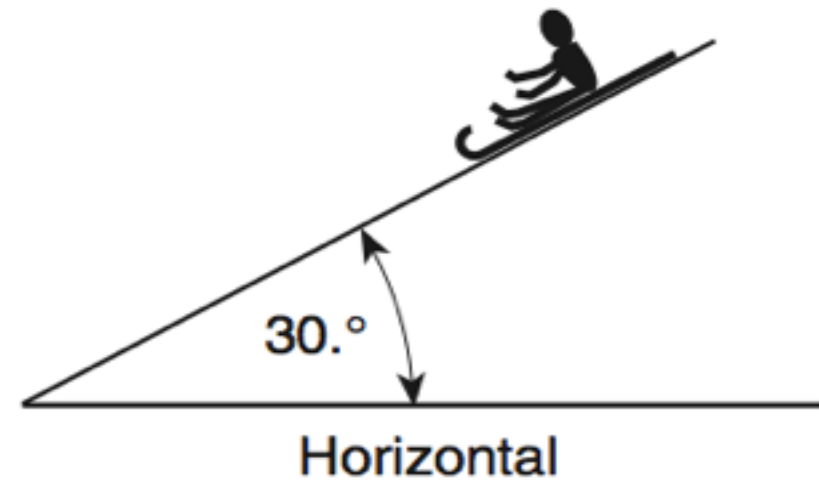

A sled and rider slide down a snow-covered hill that makes an angle of  $30^\circ$  with the horizontal. Which vector best represents the direction of the normal force,  $F_N$ , exerted by the hill on the sled?

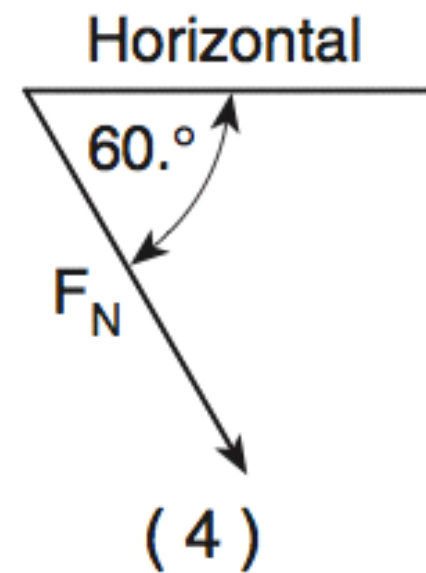
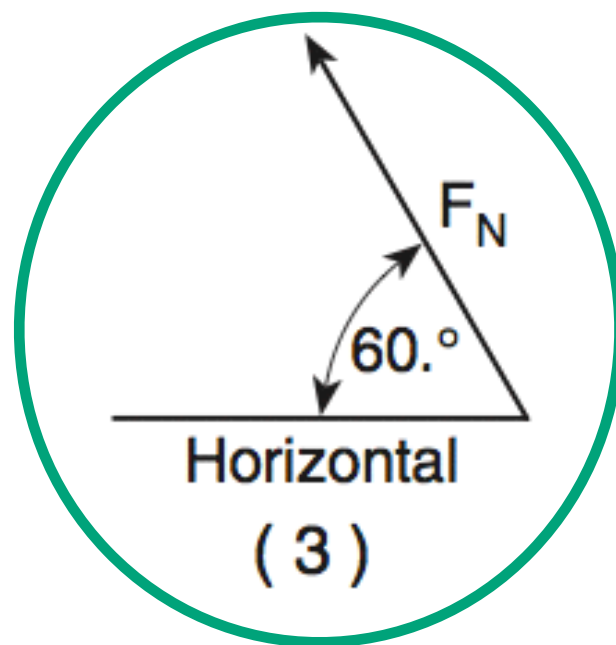
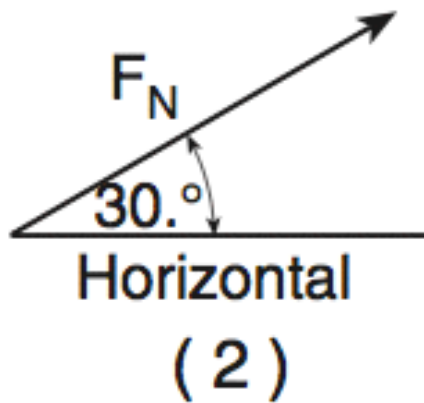
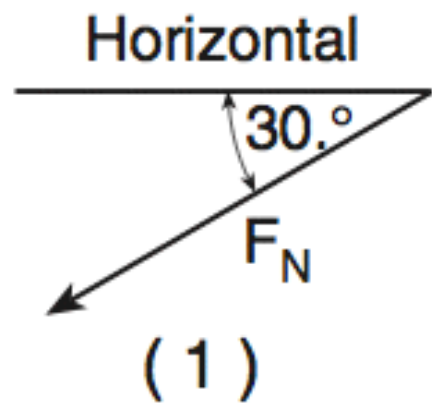
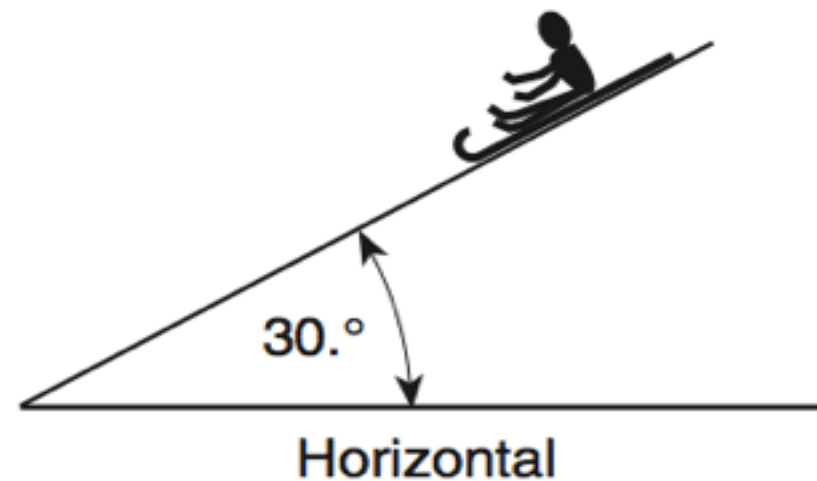

Which body is in equilibrium?

- (A) a satellite orbiting Earth in a circular orbit
- (B) a ball falling freely toward the surface of Earth
- (C) a car moving with a constant speed along a straight, level road
- (D) a projectile at the highest point in its trajectory



Which body is in equilibrium?

- (A) a satellite orbiting Earth in a circular orbit
- (B) a ball falling freely toward the surface of Earth
- (C) a car moving with a constant speed along a straight, level road**
- (D) a projectile at the highest point in its trajectory



$$F = ma$$

What is the weight of a 2.00-kilogram object on the surface of Earth?

- (A) 4.91 N
- (B) 2.00 N
- (C) 9.81 N
- (D) 19.6 N



What is the weight of a 2.00-kilogram object on the surface of Earth?

- (A) 4.91 N
- (B) 2.00 N
- (C) 9.81 N
- (D) 19.6 N**





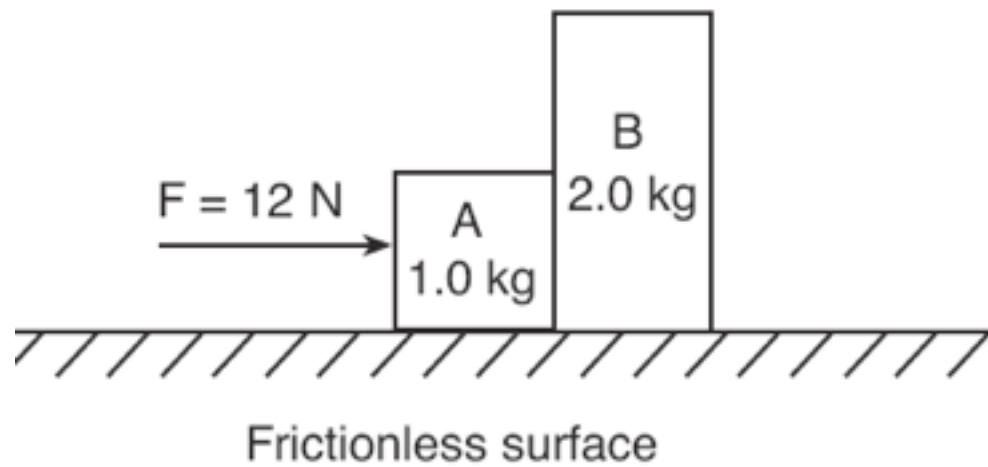

The magnitude of the acceleration of block  $B$  is

- (A)  $6.0\text{ m/s}^2$
- (B)  $2.0\text{ m/s}^2$
- (C)  $3.0\text{ m/s}^2$
- (D)  $4.0\text{ m/s}^2$

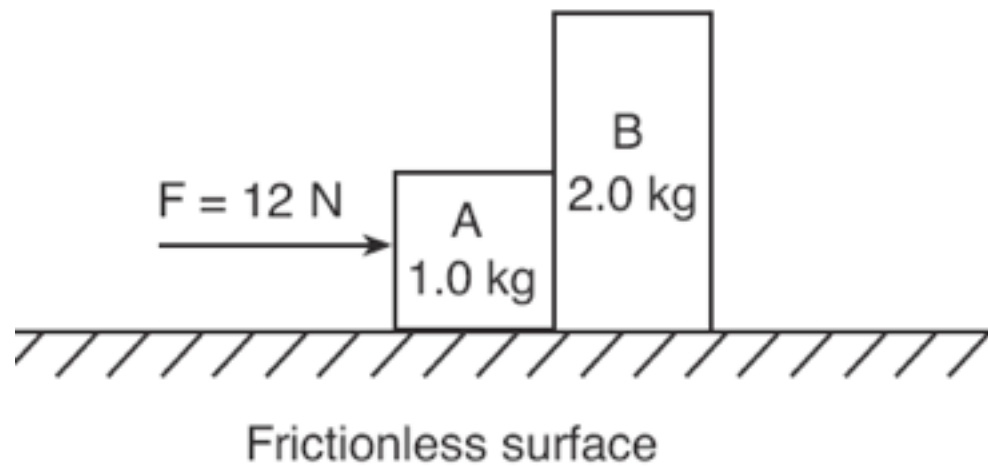

The magnitude of the acceleration of block  $B$  is

- (A)  $6.0 \text{ m/s}^2$
- (B)  $2.0 \text{ m/s}^2$
- (C)  $3.0 \text{ m/s}^2$
- (D)  $4.0 \text{ m/s}^2$**

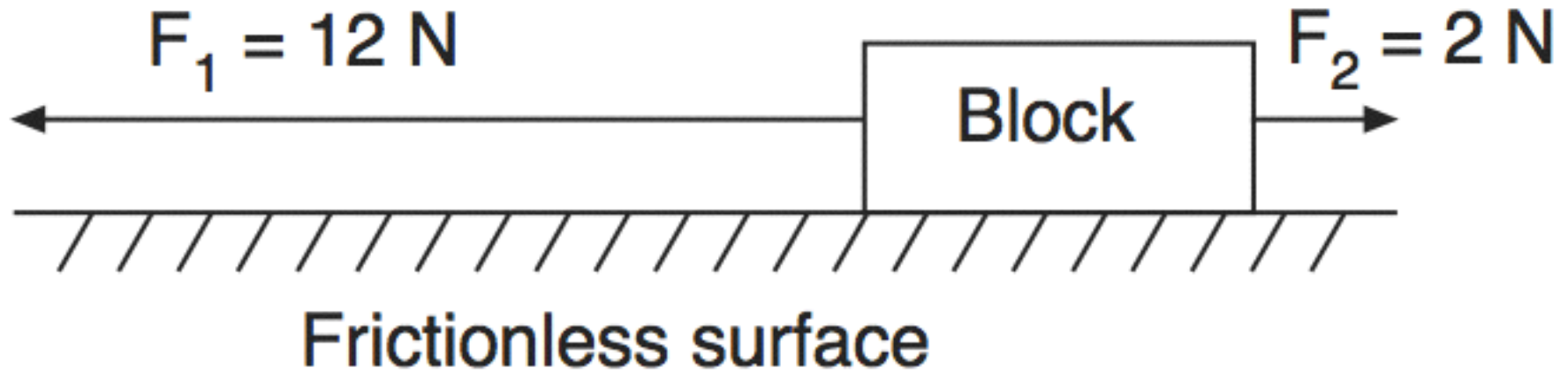

Two forces,  $F_1$  and  $F_2$ , are applied to a block on a frictionless, horizontal surface. If the magnitude of the block's acceleration is  $2.0\text{ m/s}^2$ , what is the mass of the block?

- (A) 1kg    (B) 5kg    (C) 6kg    (D) 7kg

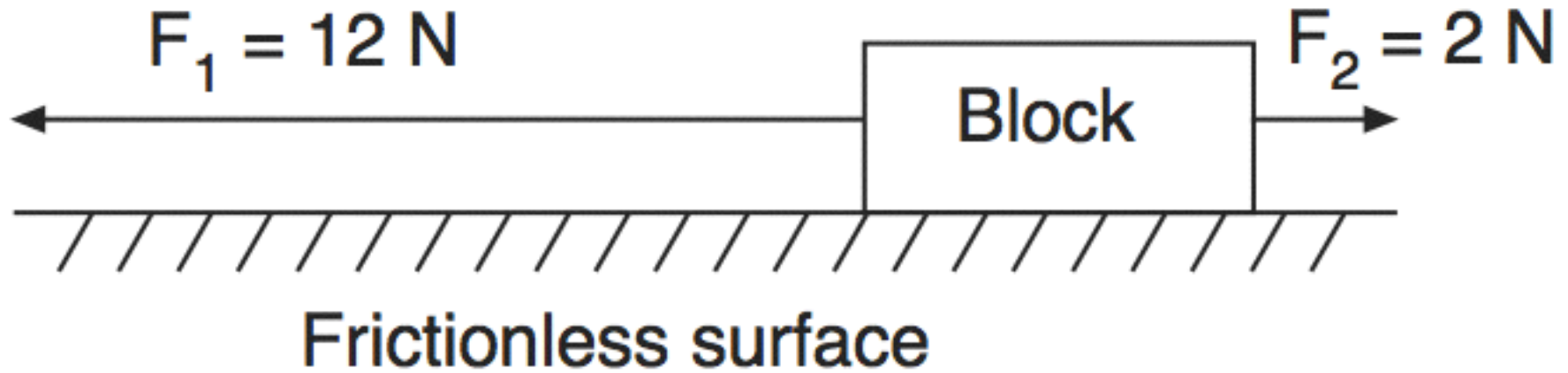

Two forces,  $F_1$  and  $F_2$ , are applied to a block on a frictionless, horizontal surface. If the magnitude of the block's acceleration is  $2.0\text{ m/s}^2$ , what is the mass of the block?

- (A) 1kg    (B) **5kg**    (C) 6kg    (D) 7kg

A person weighing 785 Newtons on the surface of Earth would weigh 298 Newtons on the surface of Mars. What is the magnitude of the gravitational field strength on the surface of Mars?

- (A) 2.63 N/kg
- (B) 3.72 N/kg
- (C) 6.09 N/kg
- (D) 9.81 N/kg



A person weighing 785 Newtons on the surface of Earth would weigh 298 Newtons on the surface of Mars. What is the magnitude of the gravitational field strength on the surface of Mars?

- (A) 2.63 N/kg
- (B) 3.72 N/kg**
- (C) 6.09 N/kg
- (D) 9.81 N/kg



A 25-N horizontal force northward and a 35-N horizontal force southward act concurrently on a 15-kg object on a frictionless surface. What is the magnitude of the object's acceleration?

- (A)  $0.67 \text{ m/s}^2$
- (B)  $1.7 \text{ m/s}^2$
- (C)  $2.3 \text{ m/s}^2$
- (D)  $4.0 \text{ m/s}^2$



A 25-N horizontal force northward and a 35-N horizontal force southward act concurrently on a 15-kg object on a frictionless surface. What is the magnitude of the object's acceleration?

**(A)  $0.67 \text{ m/s}^2$**

(B)  $1.7 \text{ m/s}^2$

(C)  $2.3 \text{ m/s}^2$

(D)  $4.0 \text{ m/s}^2$





A 60-kg physics student would weigh 1560 N on the surface of planet X. What is the magnitude of the acceleration due to gravity on the surface of planet X?

- (A)  $0.038 \text{ m/s}^2$
- (B)  $6.1 \text{ m/s}^2$
- (C)  $9.8 \text{ m/s}^2$
- (D)  $26 \text{ m/s}^2$

A 60-kg physics student would weigh 1560 N on the surface of planet X. What is the magnitude of the acceleration due to gravity on the surface of planet X?

(A)  $0.038 \text{ m/s}^2$

(B)  $6.1 \text{ m/s}^2$

(C)  $9.8 \text{ m/s}^2$

**(D)  $26 \text{ m/s}^2$**



# 3<sup>rd</sup> Law

If a 65-kg astronaut exerts a force with a magnitude of 50 N on a satellite that she is repairing, the magnitude of the force that the satellite exerts on her is

- (A) 0 N
- (B) 50 N less than her weight
- (C) 50 N more than her weight
- (D) 50 N

If a 65-kg astronaut exerts a force with a magnitude of 50 N on a satellite that she is repairing, the magnitude of the force that the satellite exerts on her is

(A) 0 N

(B) 50 N less than her weight

(C) 50 N more than her weight

**(D) 50 N**



A high school physics student is sitting in a seat reading this question. The magnitude of the force with which the seat is pushing up on the student to support him is closest to

- (A) 0N
- (B) 60 N
- (C) 600N
- (D) 6,000 N

A high school physics student is sitting in a seat reading this question. The magnitude of the force with which the seat is pushing up on the student to support him is closest to

- (A) 0N
- (B) 60 N
- (C) 600N**
- (D) 6,000 N

A carpenter hits a nail with a hammer.  
Compared to the magnitude of the force the hammer exerts on the nail, the magnitude of the force the nail exerts on the hammer during contact is

- (A) less
- (B) greater
- (C) the same



A carpenter hits a nail with a hammer.  
Compared to the magnitude of the force the hammer exerts on the nail, the magnitude of the force the nail exerts on the hammer during contact is

- (A) less
- (B) greater
- (C) the same**

A student pulls a 60-Newton sled with a force having a magnitude of 20 Newtons. What is the magnitude of the force that the sled exerts on the student?

- (A) 20 N
- (B) 40 N
- (C) 60 N
- (D) 80 N



A student pulls a 60-Newton sled with a force having a magnitude of 20 Newtons. What is the magnitude of the force that the sled exerts on the student?

- (A) 20 N
- (B) 40 N
- (C) 60 N
- (D) 80 N



Two carts are pushed apart by an expanding spring. If the average force on the 1-kilogram cart is 1 Newton, what is the average force on the 2-kilogram cart?

- (A) 1 N
- (B) 0.5 N
- (C) 0.0 N
- (D) 4 N

Two carts are pushed apart by an expanding spring. If the average force on the 1-kilogram cart is 1 Newton, what is the average force on the 2-kilogram cart?

- (A) 1 N
- (B) 0.5 N
- (C) 0.0 N
- (D) 4 N

A man is pushing a baby stroller. Compared to the magnitude of the force exerted on the stroller by the man, the magnitude of the force exerted on the man by the stroller is

- (A) zero
- (B) smaller, but greater than zero
- (C) larger
- (D) the same



A man is pushing a baby stroller. Compared to the magnitude of the force exerted on the stroller by the man, the magnitude of the force exerted on the man by the stroller is

- (A) zero
- (B) smaller, but greater than zero
- (C) larger
- (D) the same**

